

SCA-B4-70-20 (70V / 20A)
SCA-B4-70-30 (70V / 30A)



The servo-amplifiers SCA-B4-70-20 / SCA B4-70-30 are powerful PWM-modules for brushless DC motors with an output range up to 2000 Watt.

Three operation modes are integrated

- Torque-control
- Speed-control by digital-encoder feedback
- Speed-control by hallsensors

The required operation mode is to be selected from the front side of the module by setting jumpers. The SCA-B4-70-20 / SCA B4-70-30 servo amplifiers are protected against over current overheat and short-circuit of the output stage against each other or to the power supply. By the usage of advanced technology and power- MOS-FETs a high efficiency up to 95 %. Due to the wide range of power supply voltage between 11 to 70 V DC the SCA-B4-70-20 / SCA B4-70-30 can be used very flexible with different kinds of power supplies within many applications The robust aluminum case has been constructed for different methods of mounting it, therefor a fast integration is. screw terminals and a durable controller-design allow a fast and straightforward commissioning.

contents

1.	Safety notes	2
2.	specification	3
3.	preparing	3
4.	commission	5
5.	description of function of inputs and outputs	6
6.	troubleshooting	9
7.	dimensions	9
8.	versions of text	9

1. Safety notes

1.1. skilled personnel

installation and commissioning have to be done only by skilled personnel.

1.2. laws

The user has to ensure the correct installation of the servo amplifier and additional equipment according to valid laws and rules.

1.3. remove load

for first commissioning the motor should run with free shaft which means without load.

1.4. additional safety components

electronic components are not free of failure or damage. Therefore plants have to be installed with additional device and installation protecting components. A safe and stable state has to be ensured in the case of damage of some devices, wrong handling, cable disruption and other cases of any kind of malfunction.

1.5. repairs

repairs have to be done only by authorized distributors or at the manufacturer. Unauthorized opening and improper repairs of the device may cause danger to the user and the plant.

1.6. danger

care about having no power supply voltage all around the plant during installation of the device. Never touch any voltage-carrying components

1.7. maximum input voltage

the input power supply voltage must not exceed 70 V DC. Voltages exceeding 70 V or reversed connection will destroy the unit.

1.8. ESD

do not touch any of the contacts of the device

1.9. EMC

the SCA-B4-70-20 / SCA B4-70-30 is corresponds to the EC directives, standards and regulations 89/336/EEG article 10 and appendix 1 (EMV) amended by 92/31/EEG and 93/68/EEG and meet the requirements with standard EN 61800-3 (1996) if the following directions are observed:

- usage of a zinc plated mounting plate, well connected to earth
- mounting of the drive by usage of toothed washers
- usage of shielded cables to and from the unit
- large area contact of the shielding with zinc plated mounting plate.
- motor housing properly connected to earth

2. specification

		SCA-B4-70-20	SCA-B4-70-30
2.1. electrical data	power supply voltage	11- 70 V DC	
	Current (impulse)	40 A	60
	Current (nominal)	20 A	30
	frequency of power output stage	49 kHz	
	efficiency	95 %	
	bandwidth of current controller	2,5 kHz	
2.7. inputs	set value	-10...+10 V	
	encoder input signals	channel A, B; TTL max. 100 kHz	
	enable	enable 8-30 V (high-active)	
2.10. outputs	current monitor „Monitor I“	0,25 V / A	0,16 V / A
	speed monitor „monitor n“	10 V / nmax	
	supervision output Ready	Open Collector max. 30 V DC	
	auxiliary voltage source -15 V	20mA	
	auxiliary voltage source +15 V	20 mA	
	auxiliary voltage source +5 V 100 mA	voltage supply for hallsensors and encoder	
2.16. display	2-colour LED	green: ready red: error	
2.17. weight	with terminal connector	650 g	
2.18. dimensions	(LxWxH)	180 x 100 x 40 mm	
2.19. temperature-range	operation	-10...+45°C	
	storage	-40...+80°C	
2.21. humidity range	non condensing	20% -80% rel. hum.	

3. preparing

Required selection of:

- operating mode
- input for set value
- timing
- phasing
- speed range

3.1. operating mode

operating mode	Jumper setting	active potentiometers	minimal connection of control inputs
Torque Control	4	Gain; nmax: I _{max} Offset	6;9-13;17;18
Hall	7;8;9		
Encoder	5;6;7	I _{max} ; Offset	6-13;17;18

3.2. connecting diagrams

Minimalbeschaltungsvariante zur Erstinbetriebnahme

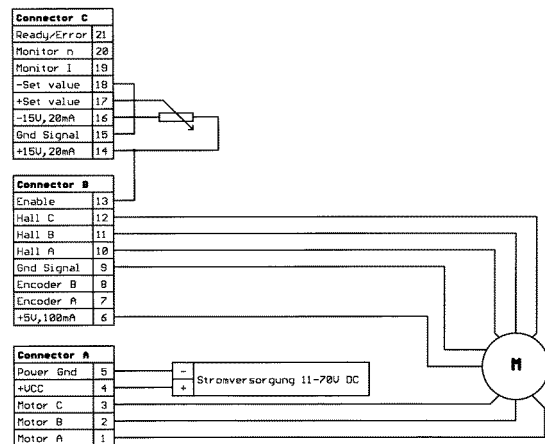

Betriebsart Torque Regelung
Hall Regelung

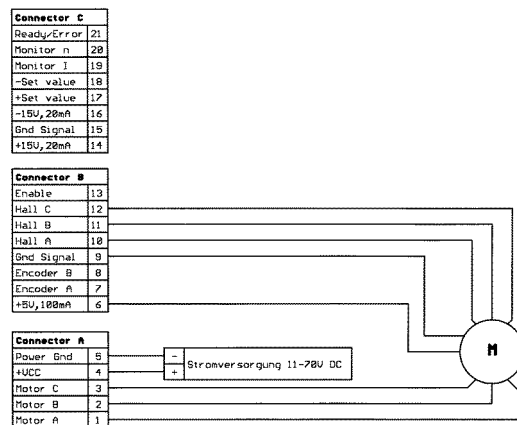

Betriebsart Encoderregelung

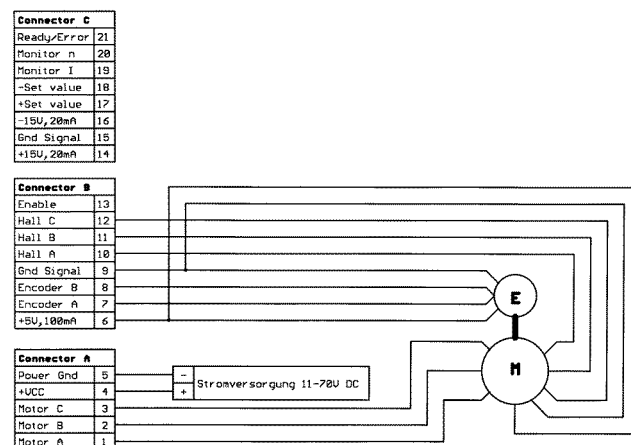

3.3. input for set value

at use of external potentiometer (min. 10 kOhm) for set value the wiper has to be connected to pin17, the others to pins 14 and 16. Pin 15 and 18 have to be connected and J 3 is to be removed. at use of the internal set value via offset potentiometer pin 15 and 18 are left without connection and J3 is to be set.

3.4. Timing

jumper J2 sets the timing of the hall sensor logic to reach an adaptation to several motor types. The setting belongs to the direction of the phases. J2 changes the rotation sense of the electrical field.

3.5. Phasing

jumper J1 is for setting the phase shift of the signals of the hall sensors. The correct value is to provide by the manufacturer of the motor (see datasheet of motor).

3.6. speed range

the speed range is to be set by jumper J10 and J 11. One of four speed ranges is to be set. The best result of speed control can be reached by setting the lowest acceptable range because of the resolution.

4. commission

4.1. selection of power supply.

Any power supply can be used as long the minimal requirements listed below are fulfilled. We recommend to remove the motor from the mechanical construction to avoid damage and danger by uncontrolled movements of

Requirements to the power supply:

output voltage: min. 11 V DC max. 70 V DC

residual voltage: < 5 %

output current: 10 A nominal, 20 A peak

4.2. funktion of potentiometers

potentiometer	function	turning ccw	turning cw
Gain coarse	gain adjustment	decreasing	increasing
Gain fine	gain adjustment	decreasing	increasing
N max	maximum speed at set value of 10 V	decreasing speed	increasing speed
I max	current limitation	decreasing min.0,3A	increasing max 10 A
Offset	adjustment n=0 at set value = 0	Motor turns cw	motor turns ccw

4.3. presetting of potentiometers

original delivered servo amplifiers are adjusted to uncritical values and for easy adjustment by the user.

4.4. adjustment

Hallcontrol Digital-Encoderregelung	1.	adjust max. set value (e.g. 10 V) and turn potentiometer n max cw til the required speed is reached.
	2.	adjust potentiometer I max to required value of current limitation. Important: Refer to motor manufacturer`s data sheet.
	3.	turn potentiometer Gain slowly cw until the required gain is reached. Important: If the motor turns rough, is vibrating or makes noise turn potentiometer ccw again, until the instability of the system is obsolete. The potentiometers Gain coarse and Gain fine work in an additive way.

	4.	adjust set value =0V and adjust potentiometer Offset until the motor stops to speed 0.
Torquecontrol	1.	. adjust potentiometer I_{max} to required value of current limitation. Important: Refer to motor manufacturer`s data sheet.

4.5. commissioning

select the required operating mode by setting the according jumpers on the left side of the unit.
Refer to the printing on the front plate.

- Required selection of:
- operating mode
 - input for set value
 - timing
 - phasing
 - speed range

connect motor, control inputs e.g. set value, enable and if necessary an additional encoder to the drive.
connect power supply.
enabling and adjustment referring to manual.

5. description of function of inputs and outputs

In () the pin number

5.1. inputs

5.1.1. Set value (17,18)

the input for set value is internally connected to an differential amplifier.
input range of set value: -10 V...+10 V
input impedance: 20 kOhm
definition of polarity: positive set value (+Set value) > (- Set value)
negative set value(+Set value) < (- Set value)

Input circuit set value:

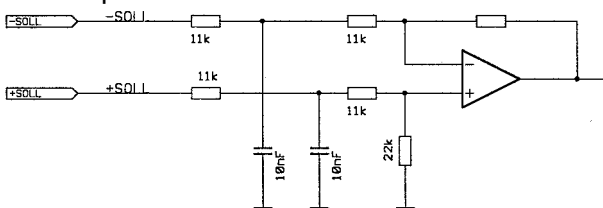

5.1.2. enable (13)

high potential at the input enable will activate speed/torque control and voltage will be applied to the motor winding. Leaving this input without connection or pulling it to the GND-potential will result in disabling the unit.

Input circuit enable:

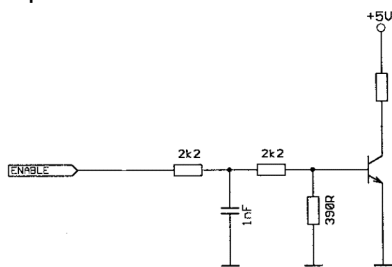

5.1.3. encoder A (7)**5.1.4. encoder B (8)**

the inputs encoder A, B are to be connected to the corresponding outputs of the encoder in operating mode speed control with encoder feedback.

Input circuit encoder:

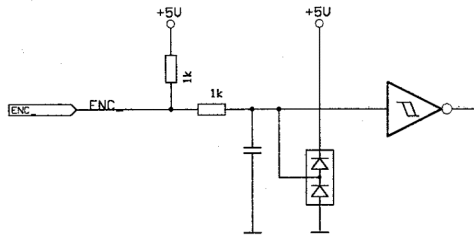
**5.1.5. Hall A (10)****5.1.6. Hall B (11)****5.1.7. Hall C (12)**

Inputs for the Hall effective sensors of the motor. The correct connection regarding phase sequence and phase relation is essential

Input circuit hall effective sensors:

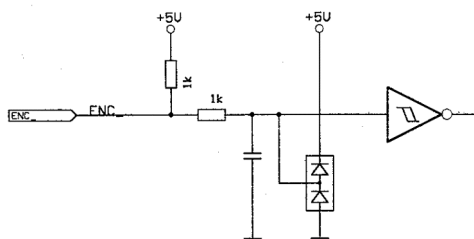
**5.1.8. power gnd (5)****5.1.9. +Vcc (4)**

power supply connection.

caution: DO not connect: +Vcc or Power Gnd to the outputs Motor A, B, or C

5.2. outputs**5.2.1. current monitor Monitor I (19)**

a current monitor for supervisory purposes is integrated to the servo amplifier. The output provides an analog signal (voltage) which is proportional to the motor current.

the monitor output is short circuit proof.

Output range: -10 V...+10 V

Output impedance: 10 kOhm

Output proportionality: 0,25V/A (SCA-B4-70-20)

Output proportionality: 0,16V/A (SCA-B4-70-30)

Output circuit current monitor:

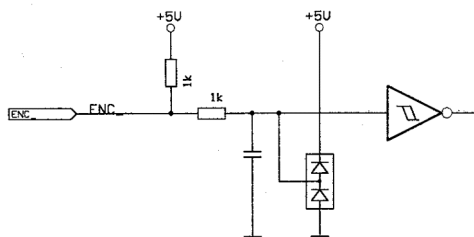

5.2.2. speed monitor Monitor n (20)

a speed monitor for supervisory purposes is integrated to the servo amplifier. The output provides an analog signal (voltage) which is proportional to the motor speed.

It can be used for qualitative weighting of the dynamic of the drive system.

Output range: -10 V...+10 V

Output impedance: 10 kOhm

Output proportionality: 10V at maximum speed

Output circuit speed monitor:

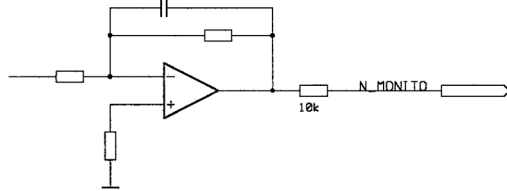

5.2.3. supervision signal Ready / Error (21)

The ready-signal is to show the status of the drive and can be used to provide a feedback signal to other devices and controls. The open-collector output is normally turned off which means the output is pulled to a positive level by an external connected resistor, if there is no fault within the drive system. In the case of a fault like under voltage, overvoltage, overheat or overcurrent the internal transistor is on, the output is pulled to GND.

Input range max. 30 V DC

load current < 20 mA

any fault is stored and can be reset by enable off and on.

Output circuit ready/error signal:

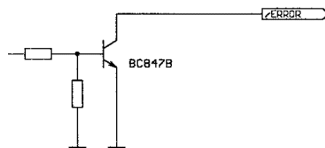

5.2.4. Motor C (3)

5.2.5. Motor B (2)

5.2.6. Motor A (1)

motor connection.

5.2.7. + 5 V, 100 mA (6)

auxiliary voltage source for power supply of hallsensors and/or incremental encoder

5.2.8. + 15 V 20 mA (14)

5.2.9. - 15 V 20 mA (16)

auxiliary voltage source for use as reference voltages by setting the set value by the means of an external potentiometer

6. troubleshooting

symptom	operating mode	causes	repair
motor does not turn	all	power supply voltage < 11 V	check power supply
		enable not active	check level at pin 14
		set value = 0V	check set value
		current limitation adjusted too low	check potentiometer adjustment I max
		speed range too low	check potentiometer adjustment n max
		wrong operation mode	check jumper setting
no speed control	speed control encoder feedback	bad connections	check connectors
		wrong wiring	check wiring
	speed control hall feedback	encoder signals	check signals and sequence
		gain adjusted too low	check potentiometer adjustment gain coarse and gain fine

7. dimensions

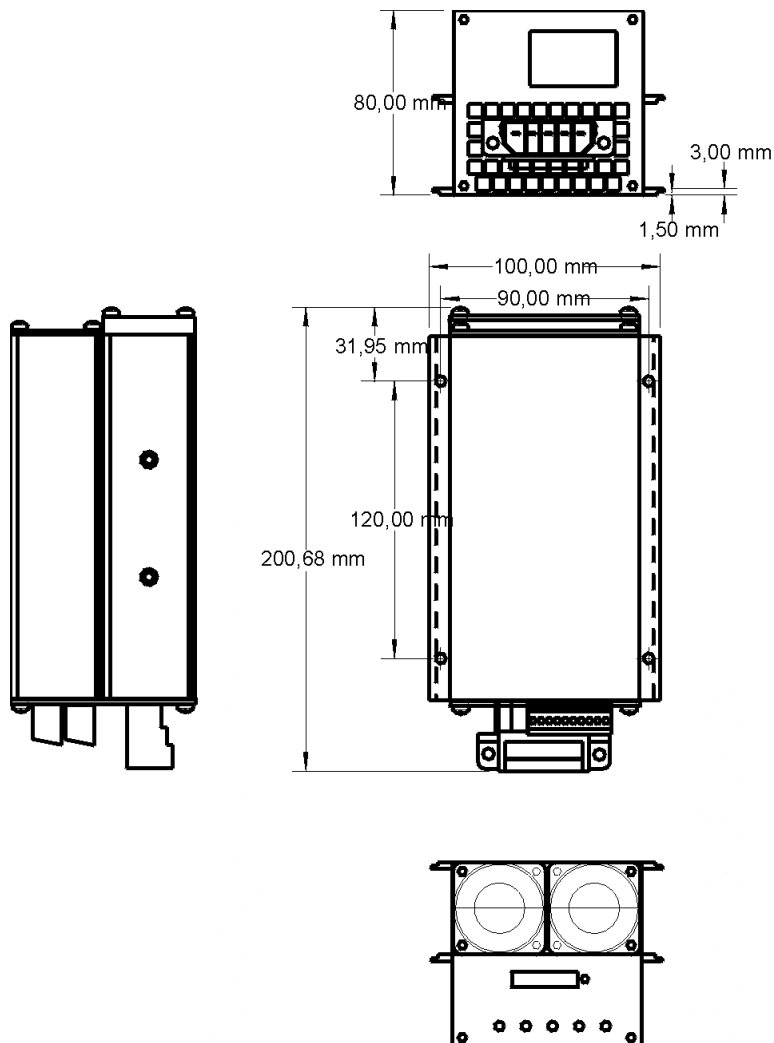

8. versions of text

V1.0 (10/00) original version

V1.1 (01/01) changed description of the error output.